

# UpRight

# SL-26N

## SELF-PROPELLED LIFTS

- 10m (32ft) working height
- High platform capacity- 680kg (1500lbs)
- Large platform area - 1.52 x 3.66m (60in x 144in)
- Proportional drive and lift controls for smooth, precise operation
- Electric, Diesel or dual fuel power
- Optional Roll-out deck extension



# UpRight

# SL-26N

## SELF-PROPELLED LIFTS

### FEATURES AND SPECIFICATIONS (All Models)

- Working height: 10m (32ft)
- Platform height: maximum. 8m (26ft)  
minimum. 1.29m (51ft)
- Driveable height: 8m (26ft)
- Maximum platform capacity: 680kg (1500lbs)\*
- Platform size: 1.52m x 3.66m (60in. x 144in.)
- Control system: proportional, single axis joystick with thumb rocker steering and interlock switch
- Dimensions:
  - Overall height: 2.40m (94.5in.)
  - Overall length: 3.79m (149in.)
  - Wheelbase: 2.54m (100in.)
  - Overall width: 1.68m (66in.) with standard tyres
- Ground clearance: axle 200mm (7.76in.)  
chassis: 320mm (12.5in.) with standard tyres
- Turning radius (inside): 2.97m (9ft.9in.)
- Drive: dual rear wheel with hydraulic motors
- Parking brake: spring applied, hydraulic released
- Tyres B78-13ST slab Electric /DF: Terra Grip on Diesel
- Guardrails: fold down with gate, 1.11m (43.5in.) high
- Toeboards: 150mm (6in.)
- Descent alarm
- Hour meter
- Wiring for power at platform
- Battery Condition Indicator
- Low voltage indicator

\*with foam filled flotation tyres.

600kg (1300lbs) with standard air filled tyres

### OPTIONAL FEATURES

- 110V AC 60 Hz generator
- Flashing amber beacon/horn
- High flotation terragrip tyres (standard on diesel)
- Poly filled tyres
- High flotation sofrac tyres
- 3 cylinder 24.5 HP Water cooled Kubota dual fuel engine
- BI-Energy diesel and electric power

### FEATURES AND SPECIFICATIONS (Specific Models)

Item	Dual Fuel	Electric	Diesel
Energy Source	20HP Kohler Dual Fuel, Dual Fuel, 2, Cylinder, air cooled engine (gasoline/propane)	Two 24V DC motors 8 x 6 V 220 A4 Batteries	18HP Kubota Water cooled Diesel engine
Battery Charger	N/A	220V / 110V 40 amp 50HZ Dual voltage	N/A
Lift Speeds			
Raise	20 sec.	33 sec.	20 sec.
Lower	35 sec.	35 sec.	35 sec.
Gradeability	30%	25%	30%
Drive Speeds			
Platform Lowered	5.0kmh	4.2kmh	5.0kmh
Platform Raised	0.8kmh	0.8kmh	0.8kmh
Weight	2,100kg	2,247kg	2,333kg

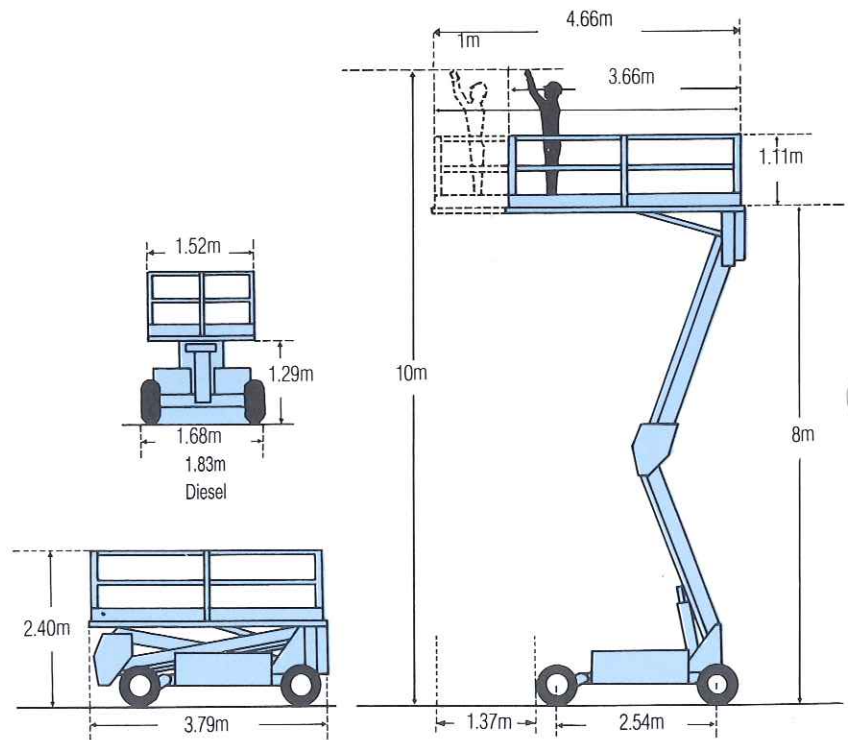

\*Maximum capacity on deck extension is 226kg (500lbs)

Manufactured by  
**UpRight**



PRIORY LODGE CHURCH ROAD BLURTON  
STOKE-ON-TRENT ST3 3BG

TEL: 01782 596 006  
FAX: 01782 336 641

22851/KIM/2-96

1998/2-95