

UpRight SL20D

Self-Propelled Lifts

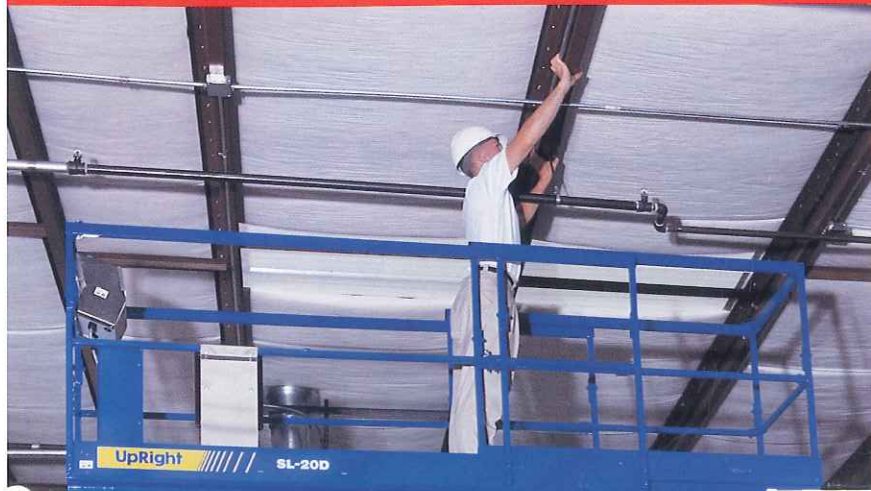

- ◆ 26 ft. working height
- ◆ Up to 750 lbs. platform capacity
- ◆ Drives through standard doorway
- ◆ Fully proportional, joystick controller
- ◆ 4 HP DC electric motor
- ◆ Dual rear wheel drive
- ◆ Roll-out deck extension
- ◆ Optional cantilever cage for overreach



Optional 6 ft. cantilever deck provides 8 ft. (2.44 m) of overreach.

UpRight

UpRight SL20D Self-Propelled Lifts

Key Standard Features

- ◆ Dual rear wheel drive
- ◆ Fully proportional, joystick controller
- ◆ Roll-out deck extension
- ◆ Ground view grates on platform
- ◆ Integral cushion down
- ◆ Ground view grates on platform
- ◆ Lift guide attachment points for crane lifting
- ◆ Heavy duty, fold down guardrails for doorways
- ◆ Tilt alarm, descent alarm

Specifications	U.S.	Metric
Platform capacity (max.) w/roll-out deck	750 lbs.	340 kg
w/optional cantilever cage	650 lbs.	294 kg
	550 lbs.	250 kg
Platform size (inside)	30 in. x 98 in.	.77 m x 2.49 m
Weight w/ roll-out deck w/cantilever cage	3,205 lbs.	1,454 kg
	3,400 lbs.	1,542 kg
Working height	26 ft.	7.92 m
Platform height	20 ft.	6.10 m
Max. drive height	20 ft.	6.10 m
Stowed height w/guardrails folded	93.7 in.	2.38 m
	79.5 in.	2.02 m
Length	98.5 in.	2.50 m
Length w/cantilever	127.9 in.	3.25 m
Width	32.5 in.	.83 m
Drive speed – maximum with platform raised	2.3 mph	3.70 km/h
	0.7 mph	1.13 km/h
Gradeability	25%	14 degrees
Inside turning radius	55 in.	1.40 m
Ground clearance	4 in.	102 mm
Lift speed – raise/lower	16 sec./28 sec.	16 sec./28 sec.
Toeboards	6 in.	152 mm

Control system Fully proportional, joystick controller and foot operated interlock switch

Power source 24V 4HP DC electric motor 4 x 6V 220 AH batteries

Battery charger 25 amp automatic with ammeter

Tires 16 in. (410 mm) diameter solid rubber

Parking brake Spring-applied, hydraulic-released

Meets or exceeds applicable requirements of OSHA and ANSI A92.6 – 1990.

Specifications subject to change without notice. Photos and diagrams in this brochure are for promotional purposes only. Refer to appropriate UpRight Operator's manual for detailed instructions on the proper use and maintenance of this equipment. UpRight also manufactures a complete line of scaffolding and other aerial work platforms. Contact your UpRight distributor for information on other products.

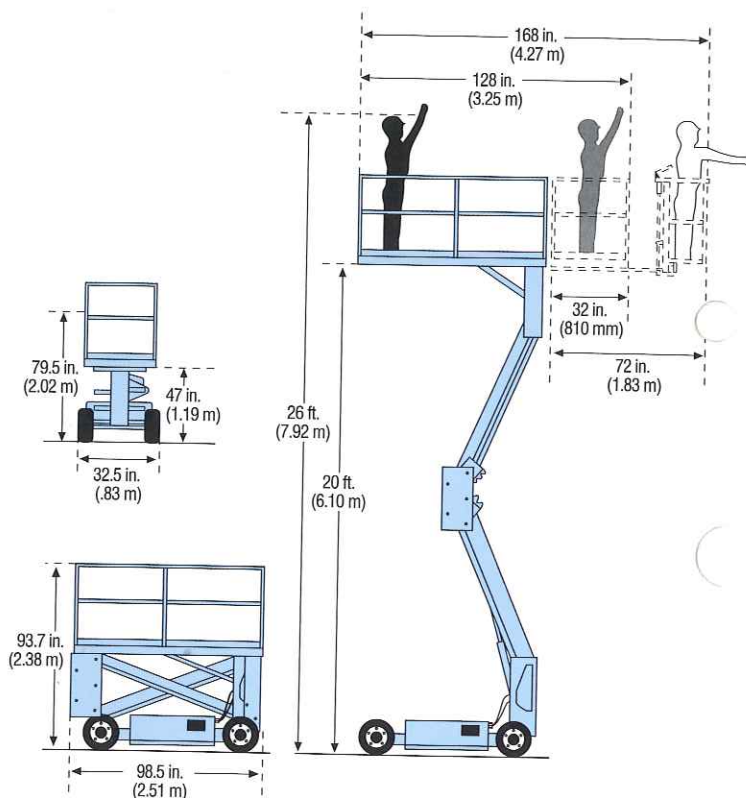

Options

- ◆ 6 ft. (1.83 m) cantilever cage extension
- ◆ 40 amp battery charger
- ◆ Aluminum diamond plate deck
- ◆ Parking brake release
- ◆ Hour meter/low voltage indicator
- ◆ Wiring for power at platform
- ◆ Non-marking tires
- ◆ Flashing amber beacon
- ◆ Reverse alarm
- ◆ Removeable controller

UpRight

USA (800) 926-5438, (209) 896-5150, FAX: (209) 896-9012

1775 Park Street, Selma, CA 93662

Europe (353) 1-285-3333 FAX: (353) 1-284-0015

Pottery Road, Dun Laoire, Ireland

Printed in U.S.A. Copyright UpRight, Inc. 1994. Form No. 105-940810-A+