

UpRight

SL30N

SELF-PROPELLED LIFT

- 11.0m working height
- Large 1.5m x 4.2m platform
- Proportional joystick controls
- Electric or dual fuel power
- High gradeability
- Drivable with platform fully elevated



UpRight

SL30N

SELF-PROPELLED LIFT

STANDARD FEATURES

- Proportional joystick controls
- Hour meter
- Fold Down Guardrails
- Tilt Alarm / Drive Cut-out
- Dual Disc Brakes

- Descent Alarm
- Wiring for power to platform
- Fully automatic 40amp battery charger with ammeter (electric model)

Specifications

Platform capacity (max.)	454 kg	1,000 lbs.
Platform size (inside)	1.46m x 4.22m	57.5in.x166.25in.
Weight- dual fuel electric	2,242 kg	4,942 lbs.
	2,391 kg	5,272 lbs.
Working height	11.0 m	36 ft. 5in.
Platform height	9.0 m	30 ft.
Max. drive height	9.0 m	30 ft.
Stowed height	2.40 m	94.5 in.
Length	4.39 m	173 in.
Width	1.67 m	66 in.
Wheelbase	2.54 m	100 in.
Drive speed - maximum with platform raised	5.0 km/h	3.1 mph
	0.8 km/h	0.5 mph
Gradeability - dual fuel electric	16 degrees	30 %
	14 degrees	25 %
Inside turning radius	2.97 m	9 ft. 9 in.
Axle ground clearance	200 mm	7.75 in.
Chassis ground clearance	320 mm	12.5 in.
Lift speed - raise/lower	23 sec./35 sec.	23 sec./35 sec.
Toeboards	152 mm	6 in.
Guardrails fold down with gate	1.11 m	43.5 in.

Control system	Proportional, single axis joystick with thumb rocker steering.
Power source	20 HP Kohler Dual Fuel. 2 cylinder, air cooled engine (gasoline/propane) or 2 24V DC electric motors, 8 6V 220 ampere hour batteries.
Tyres	B78-13ST slab.
Parking brake	Spring applied, hydraulic released.

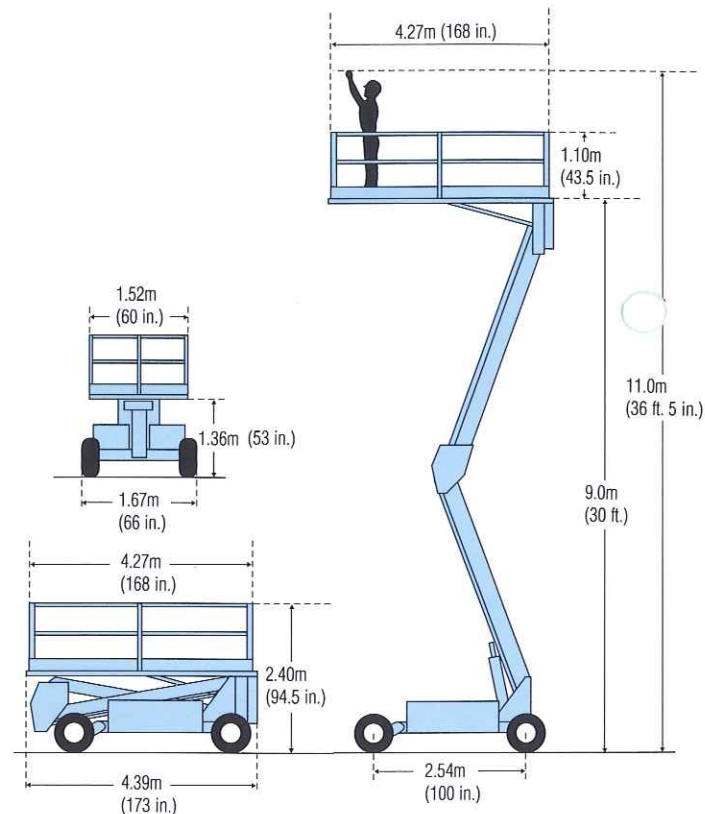

Options

- Kubota dual fuel engine, 3 cylinder, water cooled engine, 23 HP
- 110V AC generator
- Flashing amber beacon/horn
- Poly filled slab or RT tyres
- Low voltage indicator for electric

Meets or exceeds applicable requirements of OSHA and ANSI **A92.6 - 1990.**

Specifications subject to change without notice. Photos and diagrams in this brochure are for promotional purposes only. Refer to appropriate UpRight Operator's manual for detailed instructions on the proper use and maintenance of this equipment.

Manufactured by
UpRight

INSTANT ZIP-UP

INSTANT ZIP-UP LTD.
AUDLEY AVENUE, NEWPORT, SHROPSHIRE TF10 7DP
Tel: (0952) 825815 Telex: 35610 INZIP G Fax: (0952) 825635