

# UpRight

# SL30N

## SELF-PROPELLED LIFT

- 11.0m working height
- Large 1.5m x 4.2m platform
- Proportional joystick controls
- Electric or dual fuel power
- High gradeability
- Drivable with platform fully elevated

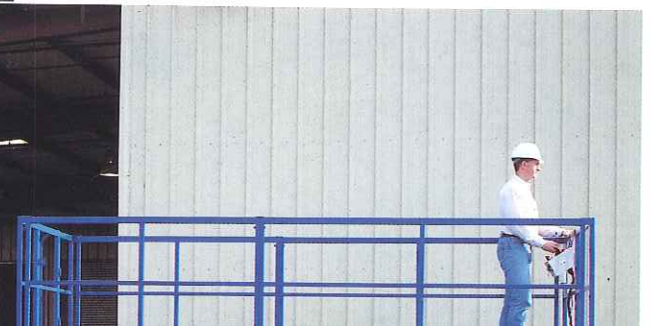

# SL30N

## SELF-PROPELLED LIFT

### STANDARD FEATURES

- Proportional joystick controls
- Hour meter
- Fold Down Guardrails
- Tilt Alarm / Drive Cut-out
- Dual Disc Brakes

- Descent Alarm
- Wiring for power to platform
- Fully automatic 40amp battery charger with ammeter (electric model)

### Specifications

Platform capacity (max.)	454 kg	1,000 lbs.
Platform size (inside)	1.46m x 4.22m	57.5in.x166.25in.
Weight- dual fuel	2,242 kg	4,942 lbs.
electric	2,391 kg	5,272 kg
Working height	11.0 m	36 ft. 5in.
Platform height	9.0 m	30 ft.
Max. drive height	9.0 m	30 ft.
Stowed height	2.40 m	94.5 in.
Length	4.39 m	173 in.
Width	1.67 m	66 in.
Wheelbase	2.54 m	100 in.
Drive speed - maximum with platform raised	5.0 km/h	3.1 mph
	0.8 km/h	0.5 mph
Gradeability - dual fuel	16 degrees	30 %
electric	14 degrees	25 %
Inside turning radius	2.97 m	9 ft. 9 in.
Axle ground clearance	200 mm	7.75 in.
Chassis ground clearance	320 mm	12.5 in.
Lift speed - raise/lower	23 sec./35 sec.	23 sec./35 sec.
Toeboards	152 mm	6 in
Guardrails fold down with gate	1.11 m	43.5 in.

Control system Proportional, single axis joystick with thumb rocker steering.

Power source 20 HP Kohler Dual Fuel. 2 cylinder, air cooled

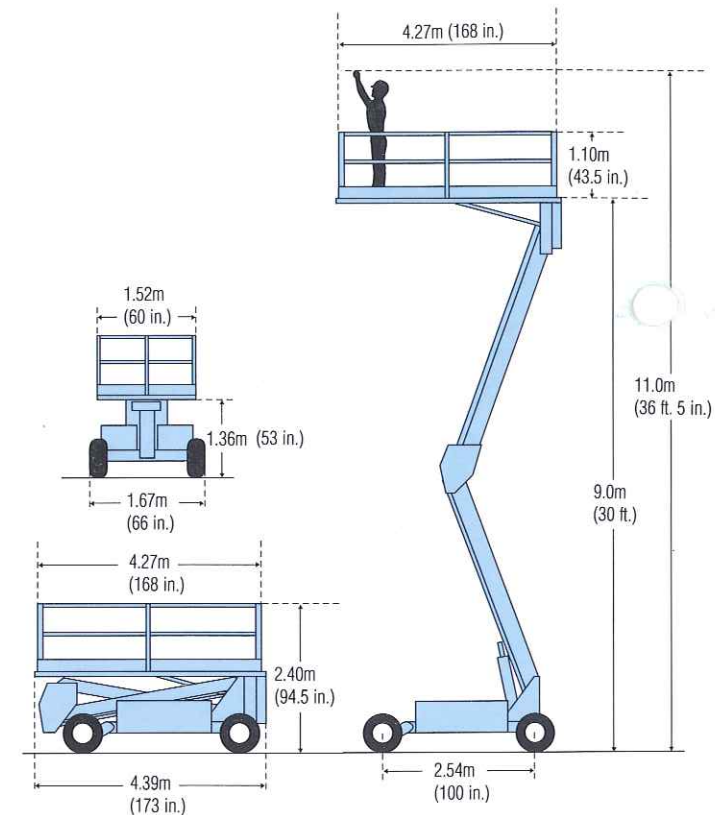

### Options

- Kubota dual fuel engine, 3 cylinder, water cooled engine, 22
- 110V AC generator
- Flashing amber beacon/horn
- Poly filled slab or RT tyres
- Low voltage indicator for electric

Meets or exceeds applicable requirements of OSHA and ANSI