

UpRight

SP35

SELF PROPELLED BOOM LIFT



- 12.7 metres working height
- 6.5 metres outreach
- Only 1.5 m wide x 3.9m long
- Direct Electric Drive
- 215kg platform capacity
- Proportional joystick control
- Telescopic upper section
- Tight turning circle
- Dual Energy option

- **COMPACT**
- **MANOEUVRABLE**
- **ENERGY EFFICIENT**
- **ECONOMICAL**

Concept Unit

SP35

SELF PROPELLED BOOM LIFT

STANDARD FEATURES

- Proportional one-hand joystick control
- Dual controls
- Battery condition indicator and low voltage cut out
- Direct Electric Drive system with dual motors and 8 x 6V 250 Ah batteries
- Foam filled low bearing pressure tyres
- Tilt alarm and cut out
- Energy-efficient motor control system for increased duty cycle between charges and smooth, precise controls
- Fully automatic on-board battery charger

SPECIFICATIONS

Max. working height	12.7 m.
Max. platform floor height	10.7 m.
Max. working outreach	6.5 m.
Platform capacity	215 Kg.
Platform dimensions (inside guardrails)	0.7 m. x 1.3 m.
Travelling Dimensions: Length Width Height	3.9 m. 1.5 m. 1.98 m.
Wheelbase	2.0 m.
Turning radius (inside)	1.50 m.
Gross weight	3400 Kg.
Gradeability	25%
Rotation	360° non-continuous
Power source	48V DC, 8 x 6V 250 Ah batteries or optional dual energy diesel generator/48V DC electric system
Control system	One-hand proportional joystick operating energy-efficient motor control system.
Drive system	Dual rear wheel direct electric drive via drive motors acting directly on planetary gear reduction drive hubs
Tyres	550mm dia. foam filled soft trac low bearing pressure/narrow option
Brakes	Dual wheel spring-applied, hydraulic released

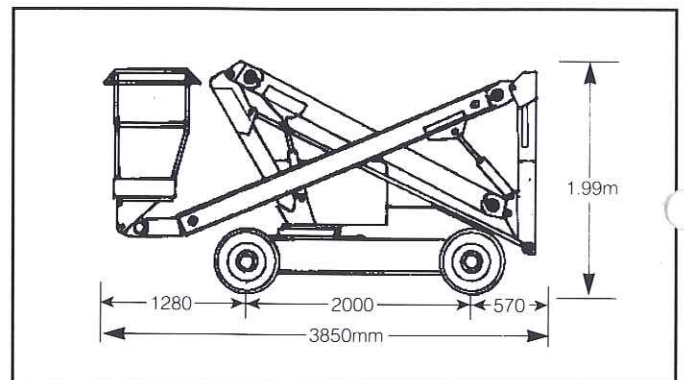
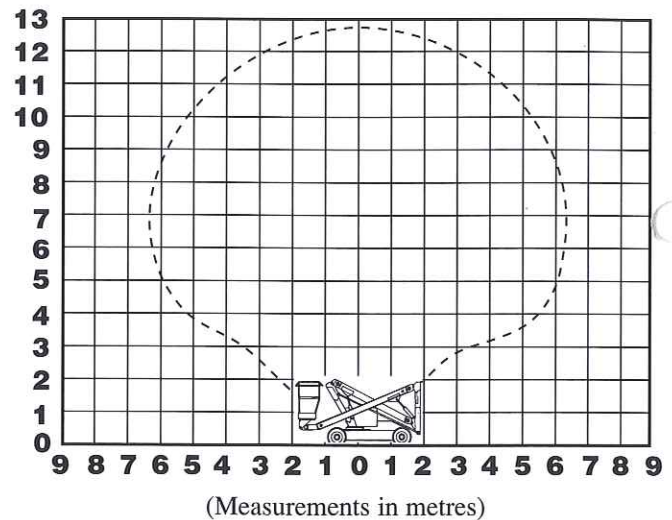

All specifications are provisional and subject to revision without prior notice

Manufactured by
UpRight

EUROPE (353) 1- 2853333

Pottery Road, Dun Laoire, Ireland.

USA (800) 926-5438

1775 Park St., Selma, CA 93662.

CANADA (800) 461-4901

108 Industrial Dr., Whitby, Ontario, Can L 1N5Z8.