

**NEW**

# UpRight

# TL49

## TRAILER MOUNTED LIFT



- 17.0 metres working height
- 8.5 metres outreach at 6.5 metres height
- Compact dimensions
- Hydraulic outriggers
- 215kg platform capacity
- One hand proportional joystick control
- Telescopic upper section for maximum versatility



# UpRight

# TL49

## TRAILER MOUNTED LIFT

### STANDARD FEATURES

- Proportional one-hand joystick control
- Dual controls
- Large platform
- Powerful 24V DC motor and 220 Ah batteries
- Hydraulic outriggers
- Outrigger interlocks and warning alarm
- Energy-efficient motor control system for unrivalled battery life and smooth, precise controls
- Fully automatic on-board battery charger

### SPECIFICATIONS

Max. working height	17.0 m.
Max. platform floor height	15.0 m.
Max. working outreach	8.5 m.
Platform capacity	215 Kg.
Platform dimensions (inside guardrails)	0.7 m. x 1.3 m.
Travelling Dimensions:	
Length	5.9 m.
Width	1.6 m.
Height	1.99 m.
Stabiliser spread	3.7m
Gross weight	1900 Kg.
Rotation	360° non-continuous
Power source	24V DC 4HP, 4 x 6V 220 Ah batteries
Outrigger type	Hydraulically operated with individual controls, lock valves and interlocks to prevent boom operation until all outriggers are taking load
Control system	One-hand proportional joystick operating energy-efficient motor control system.
Wheels	Plated steel disc road wheels fitted with 6.70-13c tyres
Braking	Automatic reverse and overrun brakes plus handbrake

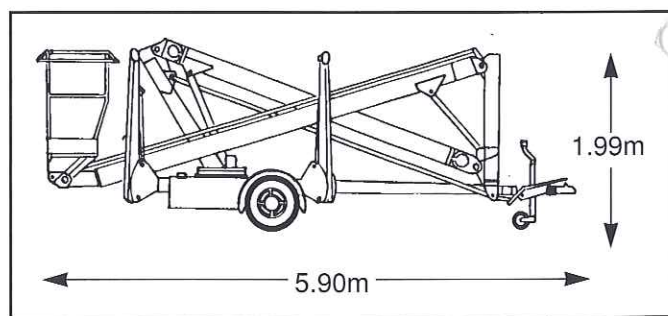
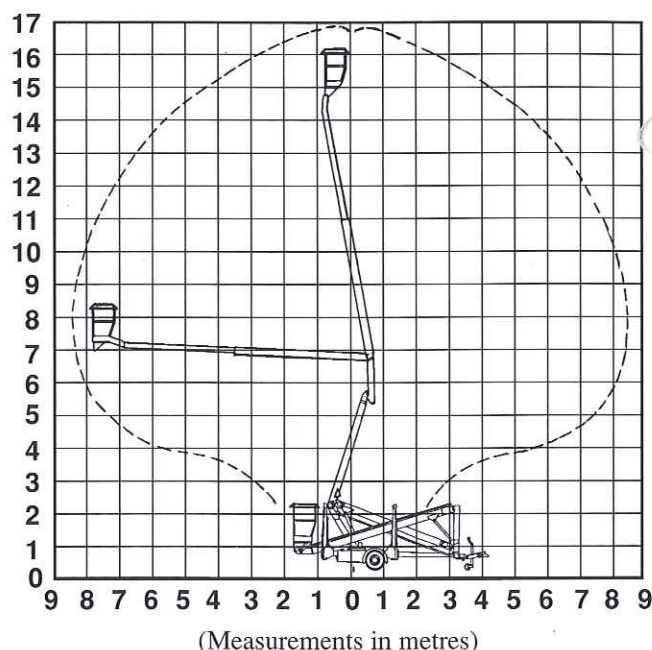

Manufactured by  
**UpRight**

All specifications are provisional and subject to revision without prior notice

**INSTANT ZIP-UP**

INSTANT ZIP-UP LTD  
AUDLEY AVENUE, NEWPORT, SHROPSHIRE TF10 7DP  
TEL: (01952) 825815 FAX: (01952) 825635