

SERVICE BULLETIN

Machines/Models: X-Series
Work Platforms

Serial Nos.: 1000-1202

SERVICE BULLETIN: 94.7, THE INSTALLATION OF THIS KIT IS MANDATORY!

DATE: July 1, 1994

PURPOSE: Notification of requirement to change rear axles.

OPERATION REQUIRED: Replacement of both rear axles.

PARTS REQUIRED: 1- 30711-001, Rear Axle Kit.

REIMBURSEMENT: One Rear Axle Kit is being sent free of charge to the dealer of record of each work platform to which this service bulletin is applicable. Installation of the kit will take less than one hour. UpRight will reimburse the dealer of record for up to one hour of installation time at the dealer's shop rate. UpRight will also reimburse the dealer of record for reasonable travel time at the rate of USD \$25.00 per hour. Reimbursement will be made upon receipt by UpRight of a properly completed warranty claim.

PROCEDURE: REFER TO THE FIGURE ON THE FOLLOWING PAGE.

1. Block front wheels to keep the machine from rolling. Using a jack of adequate capacity, raise the rear of the machine and block with jack stands.
2. Release parking brakes by loosening jam nut and brake adjustment bolt until brakes clear the tires and the wheels turn freely.
3. Remove both rear tire and wheel assemblies.
4. Remove cotter pin, slotted nut and washer from axle.
5. Slide old axles out of the chassis and discard.
6. Install new axles in chassis.
7. Install washers and slotted nuts. Tighten nuts hand tight only.
8. Install new cotter pins, **DO NOT** back off nut to install cotter pin.
9. Install both rear tire and wheel assemblies. Torque wheel bolts to 75 Ft./Lbs. (102 Nm).
10. Tighten the brake adjustment bolt until the brakes fully engage the tires, secure bolt with jam nut.
12. Operate machine and check for proper operation and brake function.
13. Fill out warranty claim form and send to UpRight.

If you have any questions regarding this Service Bulletin, please contact the UpRight Product Support Department at (800) 926-5438, in the USA; (209) 896-5150, outside the USA; or by FAX at (209) 896-92...

SERVICE BULLETIN

Machines/Models: X-Series
Work Platforms

Serial Nos.: 1000-1202

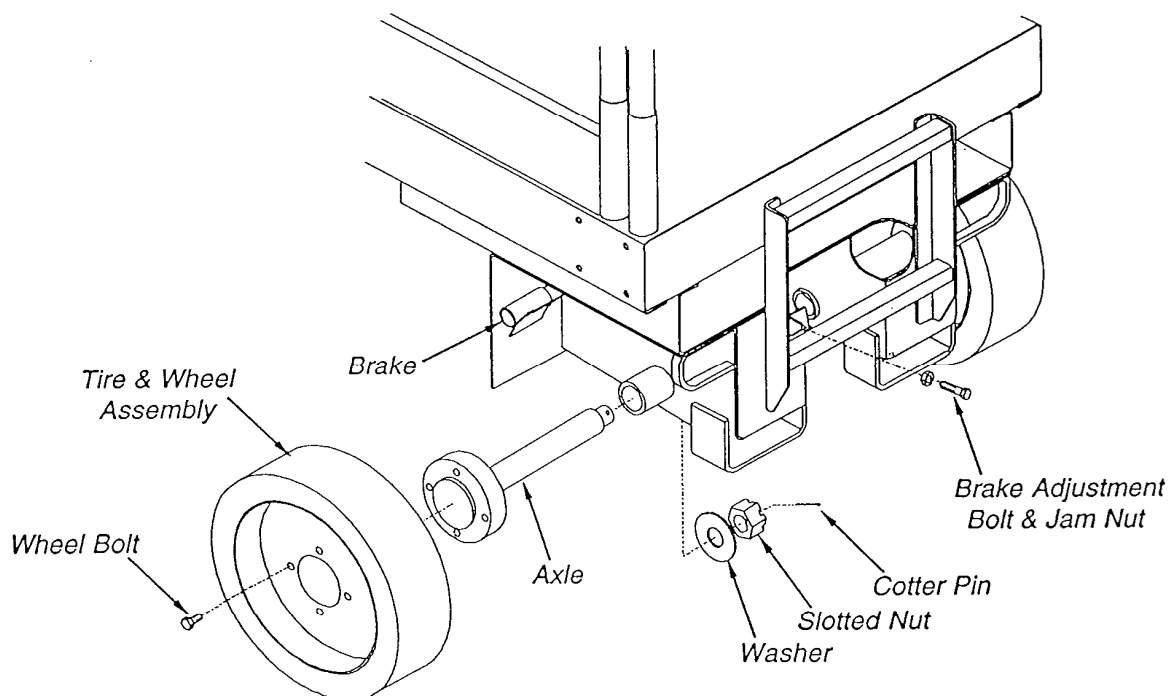

If you have any questions regarding this Service Bulletin, please contact the UpRight Product Support Department at (800) 926-5438, in the USA; (209) 896-5150, outside the USA; or by FAX at (209) 896-9244