



SERVICE BULLETIN SB04.01

Machines/Models: TM12 **Serial Numbers:** 7601 THRU 7649,7673,7677

DATE: February 01, 2004

MANDATORY COMPLETION OF THIS BULLETIN REQUIRED WITHIN 30 DAYS OF RECEIPT

PURPOSE: Replace platform due to insufficient powdercoat inside mast.

REIMBURSEMENT: UpRight will reimburse the owner of record for 3.0 hours of labor at 60.00 per hour and for travel (up to 100 miles at .50 cents per mile). Reimbursement will be made upon receipt of your warranty claim form by UpRight, Inc. Please indicate SB04.01 on claim form.

Parts Supplied:

1. 031047-000 Platform assembly
2. 026553-001 Pop-Rivet (4)
3. 031047-005 Extraction Tool (one per customer)

READ ALL INSTRUCTIONS AND REVIEW ALL FIGURES BEFORE PERFORMING THE FOLLOWING INSTRUCTIONS.

1. Raise platform approximately 30 inches and block the mast assembly as shown in **Figure 1**.
2. Disconnect batteries.
3. Tag and disconnect the control cable wires from inside the upper control box. Use extraction tool 031047-005 to remove harness wires from joystick connector.
4. Remove top cover of mast remove cable clamp securing the control cable to the mast and feed control cable from control box into mast.
6. Attach a suitable lifting device and sling to the platform and support the platform.
5. Remove retaining screws from chain anchor as shown in **Figure 1**.
7. Remove retaining screws and pry out rear slide pads from inside the bottom of the platform mast. Drill out the four rivets from the front of mast so front pads are able to slide out when platform is removed. Note orientation of front and rear wear pads.
8. Using hoist, lower platform enough to pull chain anchor and chains through access hole and continue feeding chain through access hole while raising platform. Remove platform from mast assembly.
9. Transfer access covers, document case, and control box from removed platform to platform to be installed.

** If you have any questions regarding this Service Bulletin, please contact the UpRight Product Support Department by telephone at (800) 926-5438 from within the USA or at (559) 662-3900 From Europe countries + 353 (0) 1 620 9300 (Ireland)



SERVICE BULLETIN SB04.01

Machines/Models: TM12 **Serial Numbers:** 7601 THRU 7649,7673,7677

10. Install new platform in reverse order of disassembly.

11. Reconnect batteries and test all functions.

NOTE: Reference **Figure 2** for upper control wiring.

Disposition of parts: Render platform unusable and scrap.

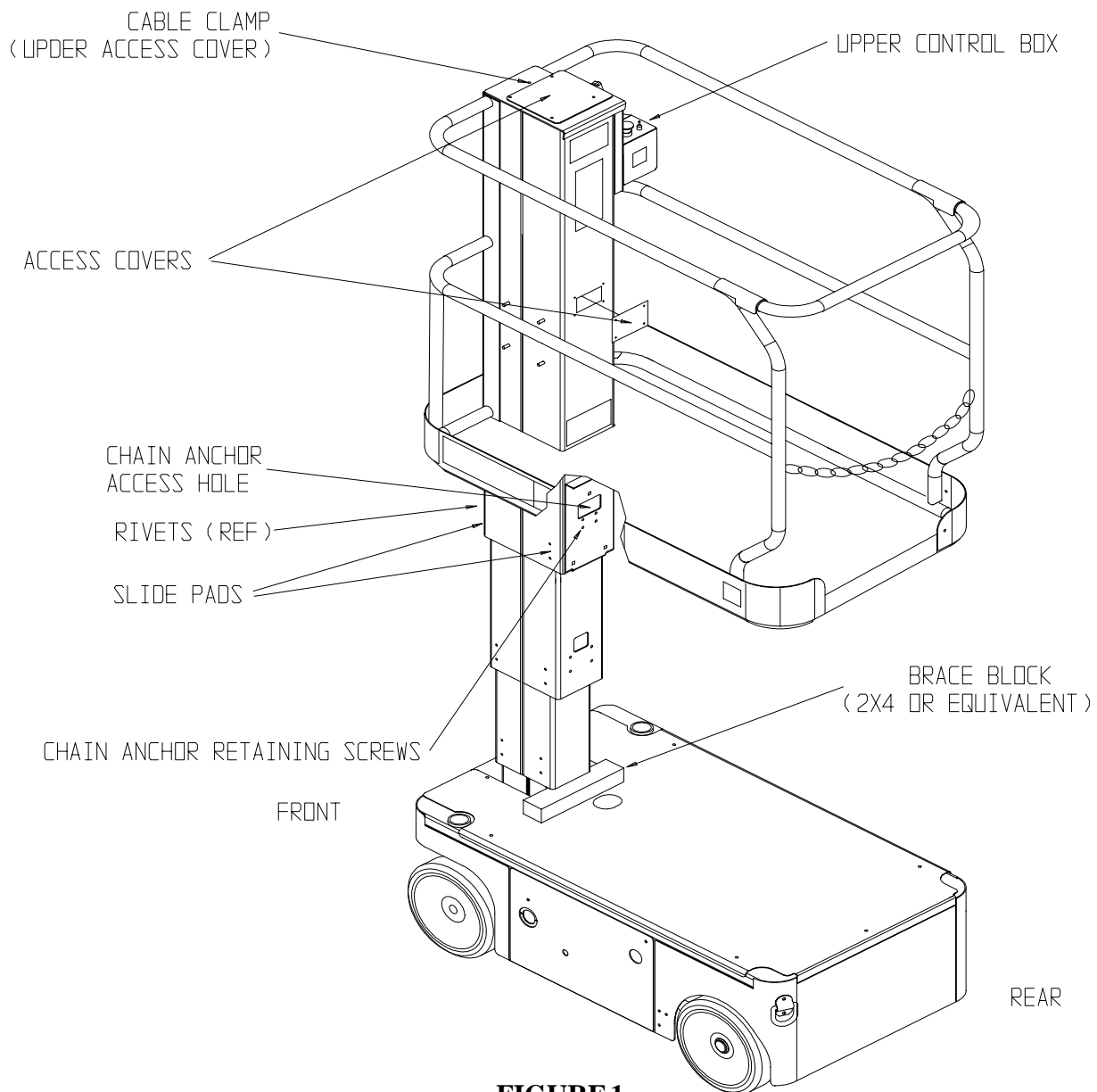

FIGURE 1

** If you have any questions regarding this Service Bulletin, please contact the UpRight Product Support Department by telephone at (800) 926-5438 from within the USA or at (559) 662-3900 From Europe countries + 353 (0) 1 620 9300 (Ireland)



SERVICE BULLETIN SB04.01

Machines/Models: TM12 Serial Numbers: 7601 THRU 7649,7673,7677

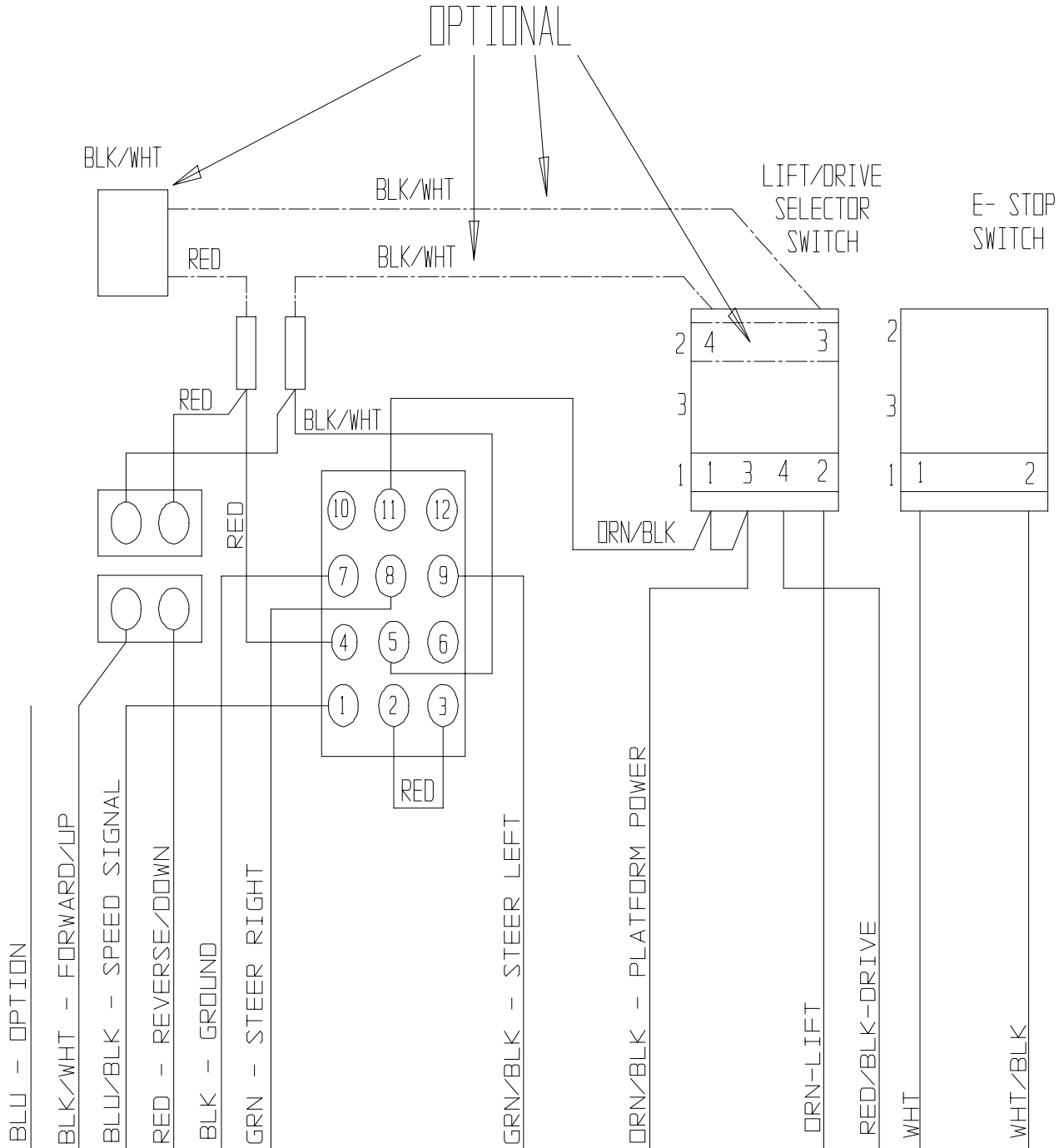

FIGURE 2

** If you have any questions regarding this Service Bulletin, please contact the UpRight Product Support Department by telephone at (800) 926-5438 from within the USA or at (559) 662-3900 From Europe countries + 353 (0) 1 620 9300 (Ireland)