

## SERVICE BULLETIN

SB98.2

Serial Numbers: 5851-6205

**Machines/Models: MX 15/19**

**THIS BULLETIN IS A SERVICE ADVISORY TO BE CARRIED OUT AT THE NEXT SERVICE INTERVAL.**

**DATE:** April 6, 1998

**PURPOSE:** Reposition Down and Tilt alarm.

**OPERATION REQUIRED:** Remove Down and Tilt alarm from chassis base, drill new mounting holes and install Down and Tilt alarm as instructed below.

**PARTS REQUIRED:** (Kit #030875-000)

4ea. Connector (029620-002)      2ea. Wire GRN/WHT-1 ft. (029482-099)  
1ea. Wire WHT-1 ft. (029451-099)      1ea. Wire ORG-1 ft. (029453-099)

**REIMBURSEMENT:** UpRight will reimburse the owner of record for 1 hour of labor at \$30.00 per hour. Reimbursement will be made upon receipt by UpRight of your completed warranty claim form. Reference this Service Bulletin Number (SB 98.2) on warranty claim.

**PROCEDURE:** Read all instructions thoroughly and refer to figures 1 - 3 before starting. Platform must be in stowed position and machine on firm level surface.

1. Locate area for Down and Tilt alarm installation. (figure 1)
2. Drill two 9/32 holes as shown. (figure 1)
3. Remove Down and Tilt alarm retaining bolts.
4. Locate Down and Tilt alarm to new location, install retaining bolts.  
**NOTE: If wire length is not sufficient, splice wires, add connectors and wires supplied with kit. (Verify existing wire color matches wires added)**
7. Perform function test as instructed in steps 8 through 15.
8. Turn chassis key switch to **CHASSIS**. Position chassis lift switch to **UP** and elevate platform approximately seven feet. (2.1m)
9. Rotate scissor brace to a vertical position. Lower platform until end of scissor arm weldment rests on brace.
10. Remove tilt sensor cover retaining screws. (figure 3)
11. Push tilt sensor (indicate) off level, tilt alarm should sound. (figure 3)
12. Reinstall tilt sensor cover and retaining screws. (figure 3)
13. Position Chassis Lift Switch **UP** and elevate platform approximately seven feet. (2.1m)
14. Return scissor brace to its stowed position.
15. Position Chassis Lift Switch to **DOWN** and return platform to its stowed position. Verify audible (Down) alarm is sounding while platform is descending.
16. If machine does not perform as described, please contact the UpRight Product Support department by telephone at (800) 926-5438.

# SERVICE BULLETIN

SB98.2

Serial Numbers: 5851-6205

Machines/Models: MX 15/19

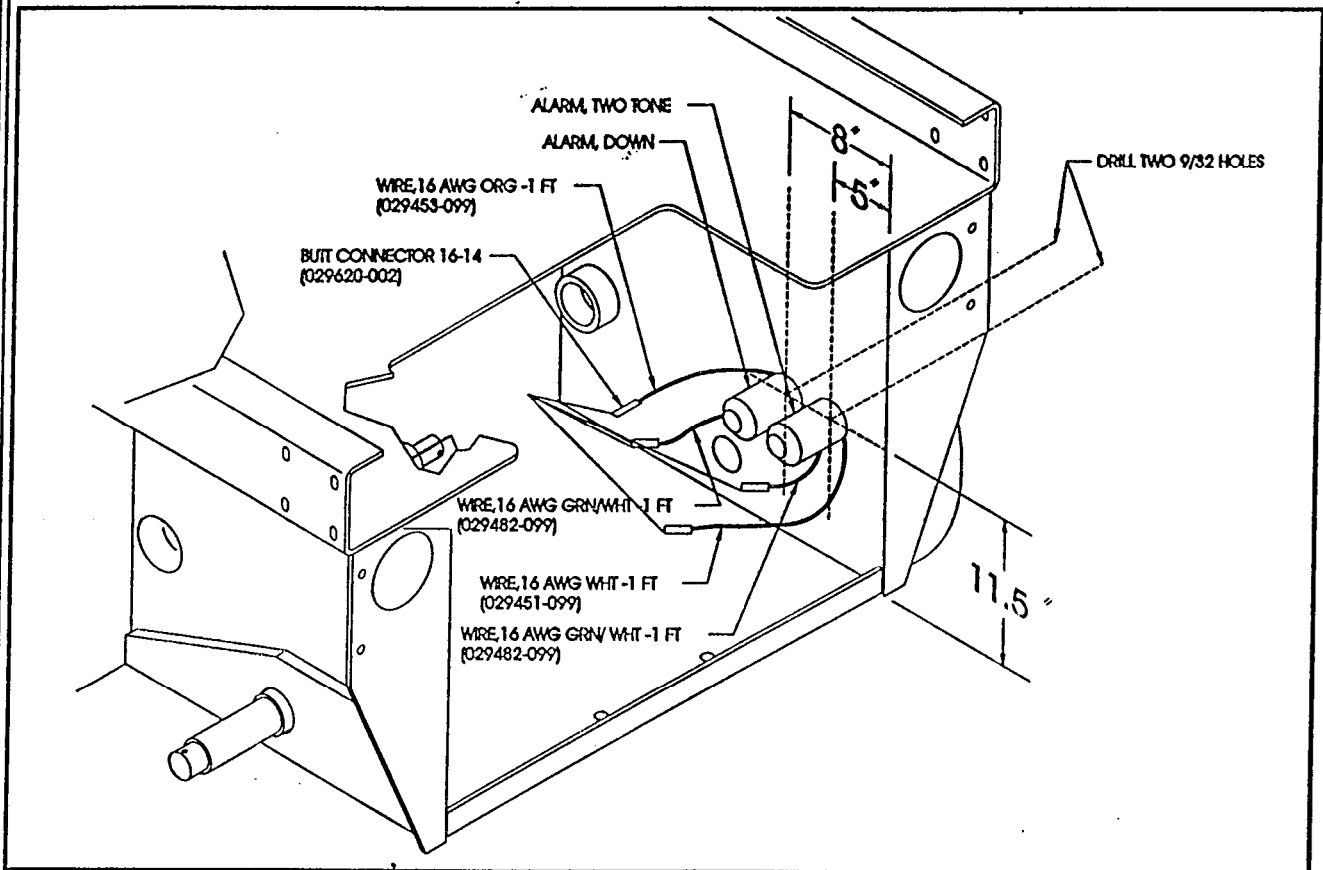

Figure 1

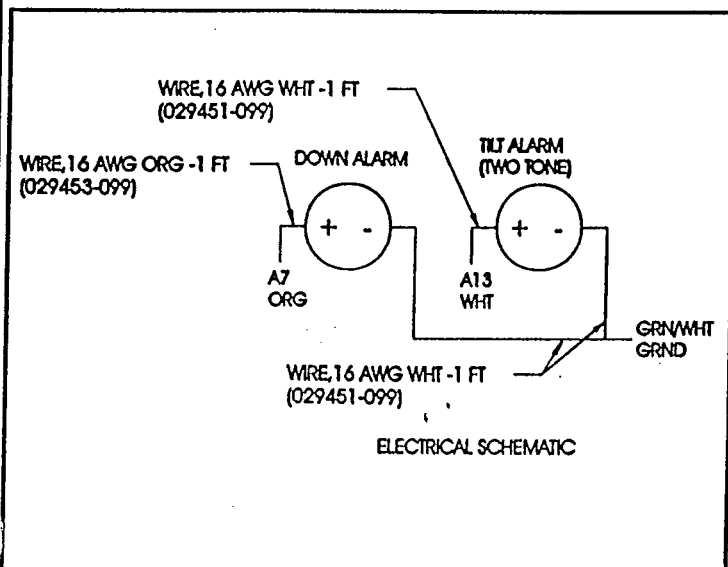

Figure 2

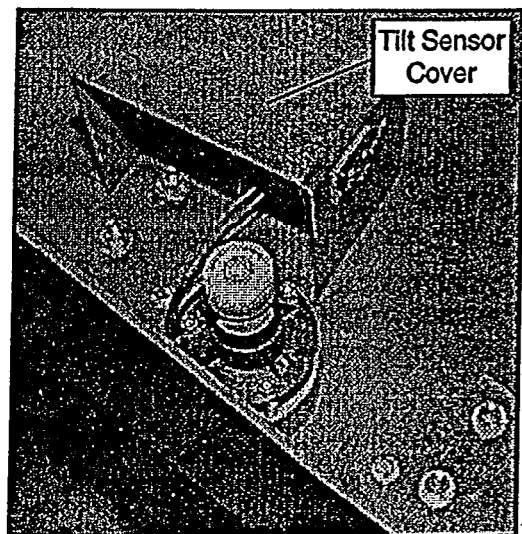

Figure 3. Tilt Sensor

If you have any questions regarding this Service Bulletin, please contact the UpRight Product Support Department by telephone at (800) 926-5438 from within the USA or at (209) 891-5200 outside the USA or by FAX at (209) 896-9244.