

SERVICE BULLETIN SB99.3B

Machines/Models: SL26/30N Gas and Diesel

Serial Numbers:
11200-12180

THIS BULLETIN IS MANDATORY.

DATE: June 1, 1999

PURPOSE: To enhance pressure protection of drive motors.

OPERATION REQUIRED: Replace rear drive motors and existing hardware.

PARTS REQUIRED: 2 Wheel Drive I/C - SB99.3B Drive Motor with Relief Kit

1. 8 ea. #011266-020 Screw 1/2-20 UNF HHC x 2 1/2
2. 8 ea. #011238-008 Lock washer 1/2 Split
3. 2 ea. #011754-012 Cotter Pin 5/32 Dia x 1 1/2
4. 2 ea. #063903-005 Hydraulic Drive Motor (Rear)

REIMBURSEMENT: UpRight will reimburse the owner of record for up to 2 hours of labor at \$35.00 per hour and for travel (up to 100 miles) at \$0.35 per mile. Reimbursement will be made upon receipt by UpRight of your completed warranty claim form. Please reference SB99.3B on your warranty claim form.

NOTE: *Due to the mandatory nature of this Service Bulletin, all work must be performed by November 30th, 1999. Any warranty credit requested after this date must have advanced approval from the Warranty Administrator.*

PROCEDURE: Read all instructions thoroughly and refer to Figure 1 before starting.
(Reference Parts & Service Manual)

REMOVAL - Rear Axle - Two Wheel Drive I/C motors-only:

1. Park the work platform on firm level surface and block the front wheels to prevent the work platform from rolling.
2. Loosen the Wheel Lug bolts on the motor to be removed.
3. Raise the rear axle of the work platform using a two-ton jack.
4. Position two one-ton jack stands under the rear axle to prevent the work platform from falling if the jack fails.
5. Remove the wheel lug bolts and wheel.
6. Remove the Cotter Pin, Slotted Nut, Hub, and Shaft Key.

NOTE: Use a wheel puller to remove hub. Using any other method of removal may damage the drive motor housing and void warranty. Clean all fittings before disconnecting the hose assemblies. Plug all hose assemblies IMMEDIATELY to prevent contamination from entering the system.

7. Tag, identify and disconnect the hose assemblies.
8. Remove the Cap Screws, Lock Washers and Drive Motor from the rear axle.

If you have any questions regarding this Service Bulletin, please contact the UpRight Product Support Department by telephone at (800) 926-5438 from within the USA or at (559) 891-5200 outside the USA or by FAX at (559) 896-9244.

SERVICE BULLETIN SB99.3B

Machines/Models: SL26/30N Gas and Diesel

Serial Numbers:
11200-12180

INSTALLATION:

1. Position the Drive Motor (#063903-005) in the rear axle and secure with Screws (#011266-020) and Lock Washers (011238-008). Torque nuts to 75 ft./lbs (102Nm).
2. Reinstall the hose assemblies.
3. Thoroughly clean the motor shaft and hub bore of all grease, paint and foreign material.
4. Reinstall the Shaft Key, Hub, and Nut. Torque each Wheel Hub Nut to 350 ft./lbs. (475 Nm). Align the slot in the Nut with the hole in the shaft and insert the Cotter Pin. DO NOT back off the Nut to align.
5. Reinstall the Wheel and Lug Bolts onto the Hub. Torque the Lug Bolts to 90 ft./lbs. (122 Nm).
6. Remove the jack stands used to block the wheels. Lower the jack and remove.
7. Operate the drive system to check for leaks.

NOTE: No adjustment is required on Drive Motor relief.

FIGURE 1

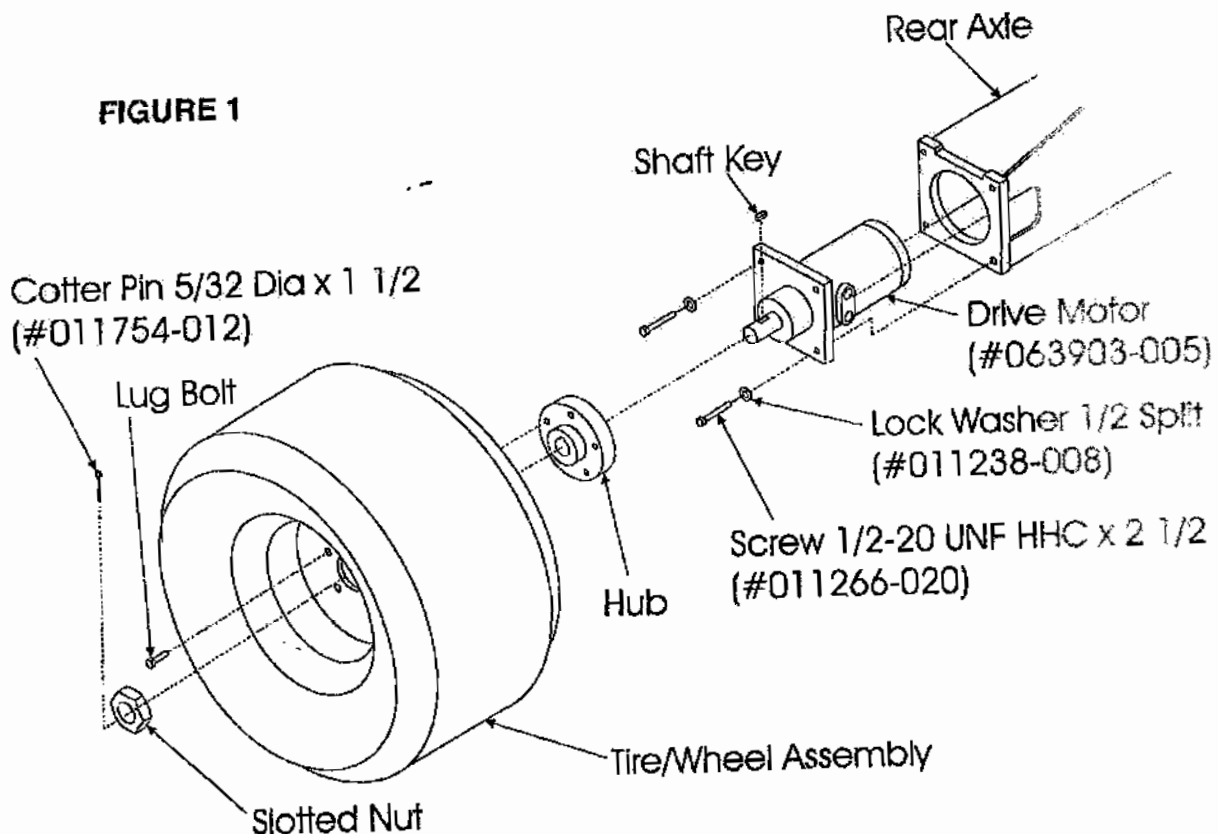

If you have any questions regarding this Service Bulletin, please contact the UpRight Product Support Department by telephone at (800) 926-5438 from within the USA or at (559) 891-5200 outside the USA or by FAX at (559) 896-9244.