



# SERVICE BULLETIN

**SB99.4****Machines/Models: AB38****Serial Numbers: 1500-1724.****THIS BULLETIN IS MANDATORY.****DATE:** February 22, 1999**PURPOSE:** Add Bushings to Lift Cylinder Trunnion mount.**OPERATION REQUIRED:** Install new Lift Cylinder Trunnions, Button Head Bolts and Bushings.**PARTS REQUIRED: Kit # SB 99.4**

2ea. Bushing Flanged 35 mm (057046-000)      2ea. Trunnion AB38 (058447-000)  
8ea. M8 X 16 Button Head Bolt (500595-016)      2ea. Grease Fitting (057048-000)

**REIMBURSEMENT:** UpRight will reimburse the owner of record for 1.5 hours of labor at \$35.00 per hour and reasonable travel at \$0.35 per mile. Reimbursement will be made upon receipt of your completed warranty claim form. Please reference SB99.4 on your warranty claim form.

**PROCEDURE:** Read all Instructions thoroughly and refer to Figures 1 and 2 before starting.

1. Place the machine on a firm level surface and elevate the Lower Boom until there is 1 ft (0.3m) clearance between the Boom and the Boom Rest. Secure Lower Boom with one-ton overhead lifting device. Turn the Keyswitch and both Emergency Stop buttons to the 'OFF' position.
2. Remove the securing Bolt and Pin Lock Plate from the Rod End of the Lower Lift Cylinder (Figure 1, item 7). Support the rod end of the cylinder and remove the rod end pivot pin. Allow the cylinder to rest against the First Post.
3. Release and remove the eight 8 mm Countersunk Head Bolts (Figure 2, item 2) and the two Grease Fittings from the existing Trunnions (Figure 2, item 3). While supporting the barrel end of the cylinder carefully remove Trunnions and discard.
4. Fit Bushings (057046-000) (Figure 2, item 4) to the Trunnion Pivot on Lift Cylinder. **It is important that the grease track of the Bushing line up with the Grease Fitting.**
5. Holding the Trunnions in place, start Button Head Bolts (500595-016) (Figure 2, item 5) in one turn. With all bolts in place torque the bolts to 18 Ft/Lbs (25 Nm).
6. Replace Grease Fittings (057048-000) into Trunnion (058447-000) and secure hand tight.
7. Rotate the rod end of the cylinder into position. Insert pin and secure Pin Lock Plate with bolt. Torque to 33Ft/Lbs (45 Nm).
8. Place rated platform capacity - 475 lbs (215 Kg) in the middle of the Platform.
9. Perform full function test of lift functions.

If you have any questions regarding this Service Bulletin, please contact the UpRight Product Support Department by telephone at (800) 926-5438 from within the USA or at (559) 891-5200 outside the USA or by FAX at (559) 896-9244.

## SERVICE BULLETIN

**SB99.4**
**Machines/Models: AB38**
**Serial Numbers: 1500-1724.**

1. Lower Lift Cylinder
2. Countersunk Head Bolt
3. Trunnion
4. Bushin
5. Button Head Bolt
6. Rod End Pivot Pin
7. Pin Lock Plate
8. First Post

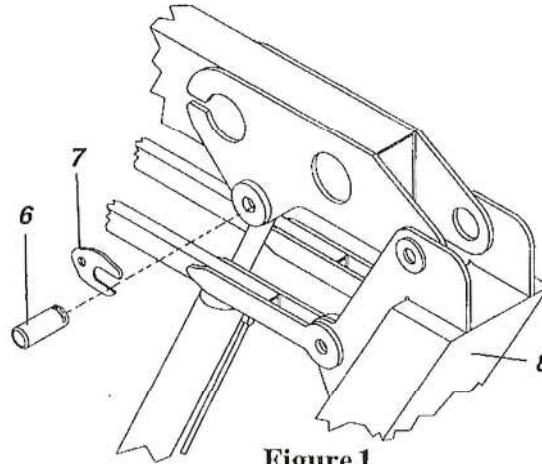
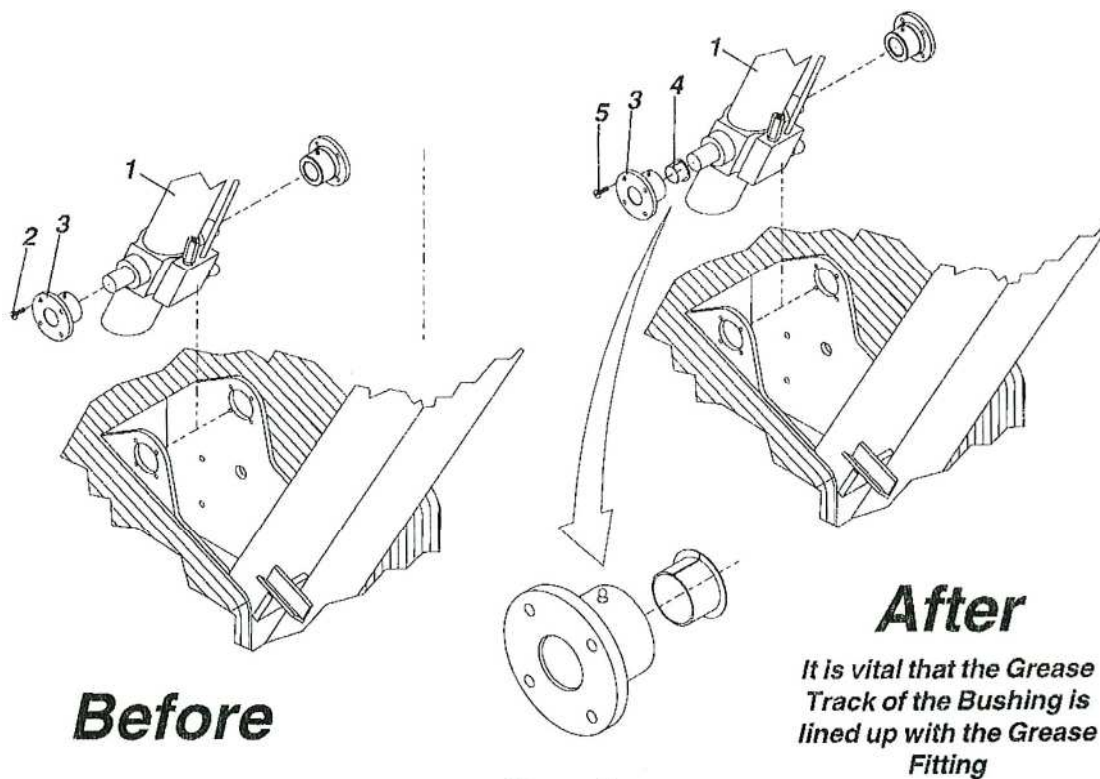
**Figure 1**

**Figure 2**

If you have any questions regarding this Service Bulletin, please contact the UpRight Product Support Department by telephone at (800) 926-5438 from within the USA or at (559) 891-5200 outside the USA or by FAX at (559) 896-9244.