

SERVICE INFORMATION LETTER SI 01.01

Machines/Models: X20N

Serial Numbers: Above 6012

DATE: January 31, 2001

PURPOSE: Inspect the Pivot Bolt in the Brake Linkage.

PROCEDURE REQUIRED: Verify that the Pivot Bolt for the Brake Linkage is not Overtightened.

PROCEDURE: At the next service interval verify that the brake linkage is not overtightened by performing the following procedure.

WARRANTY REIMBURSEMENT: Not Eeligible

1. The 3/4" bolt in Figure 1 should not be torqued, verify that a gap of .010 to .025" exists between the nut and the side of the brake adjustment weldment.

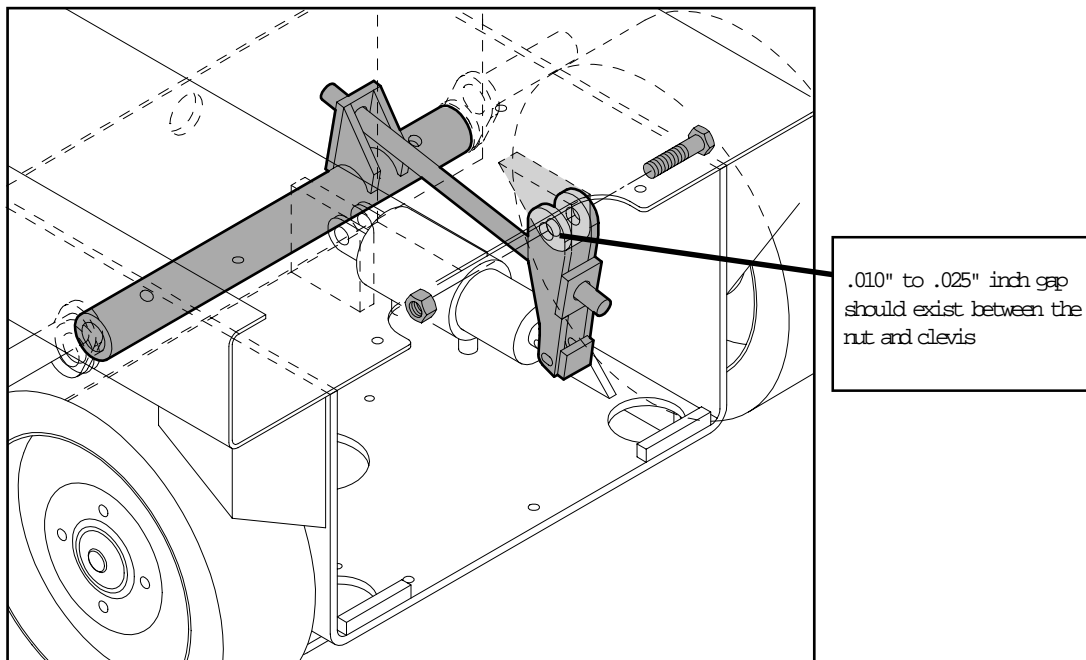

Figure 1

If you have any questions regarding this Service Information Letter, please contact the UpRight Product Support Department by telephone at (800) 926-5438 from within the USA or at (559) 891-5200 outside the USA or by FAX at (559) 891-8931.